

W. F. HUNT.
Machine for Making Plaited Paper Caps, &c.
No. 221,314. Patented Nov. 4, 1879.

Fig. 1.

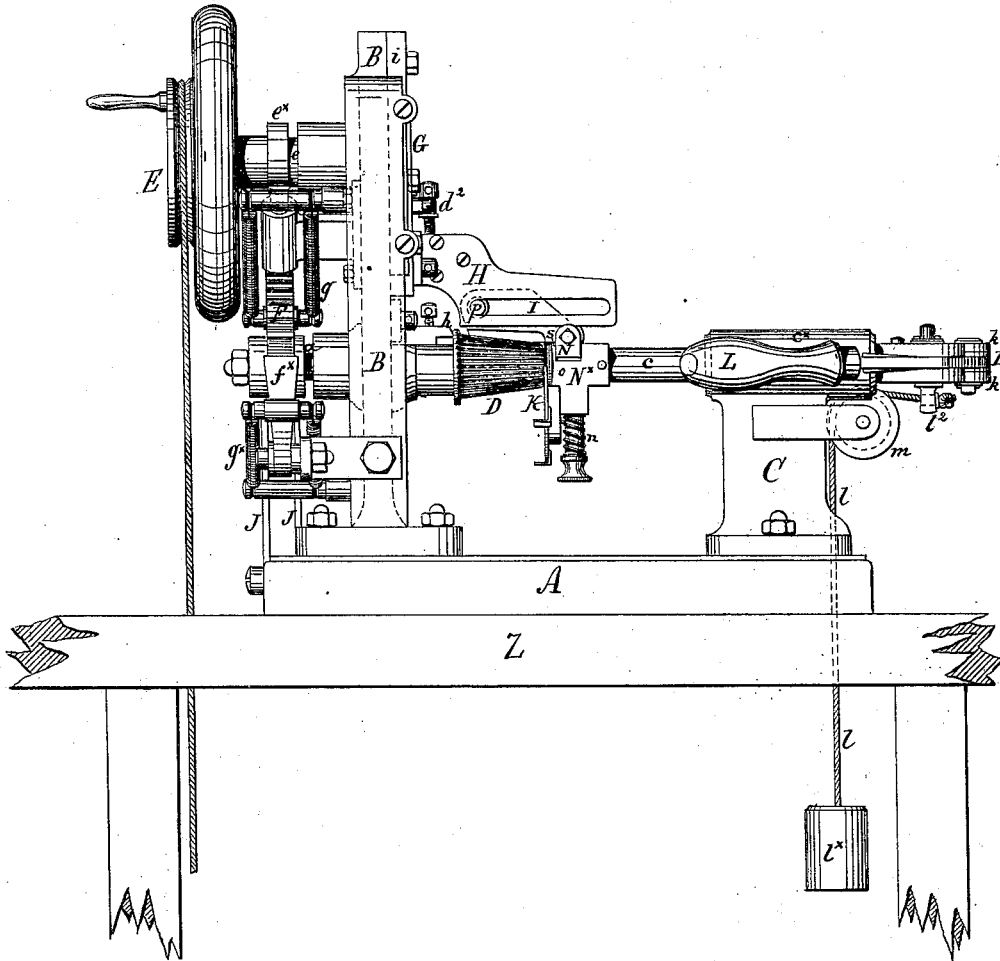

Witnesses
Ames de Lass
W. Mantus

Inventor
William Frederick Hunt

W. F. HUNT.
Machine for Making Plaited Paper Caps, &c.

No. 221,314.

Patented Nov. 4, 1879.

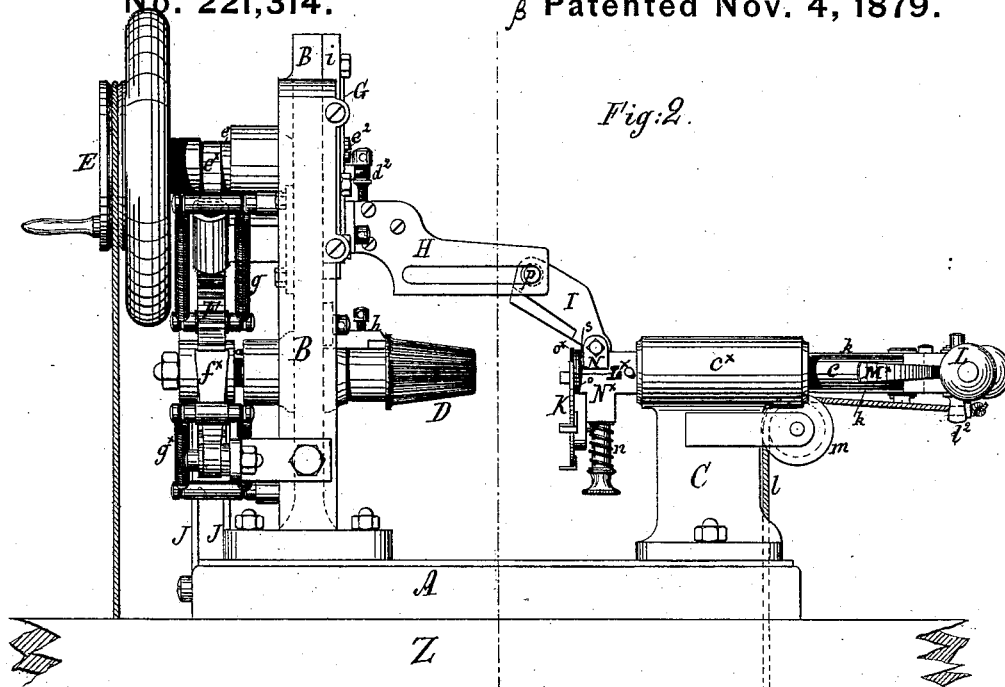

Fig. 2.

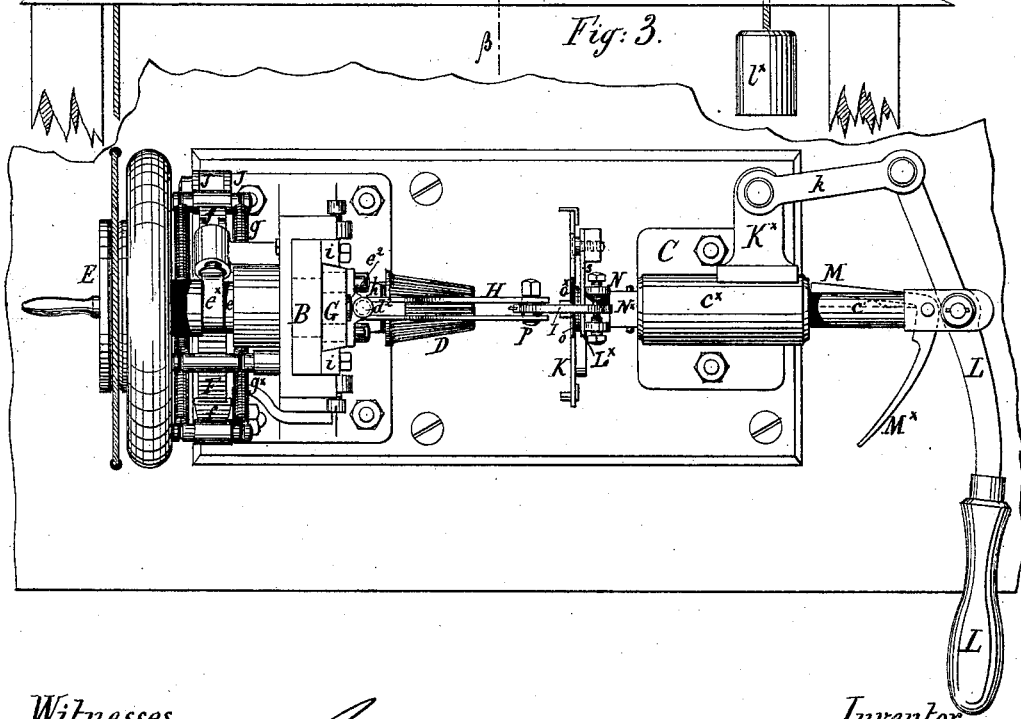

Fig. 3.

Witnesses
Ames de laas
H. Mantel

Inventor
William Frederick Hunt

W. F. HUNT.
Machine for Making Plaited Paper Caps, &c.

No. 221,314.

Patented Nov. 4, 1879.

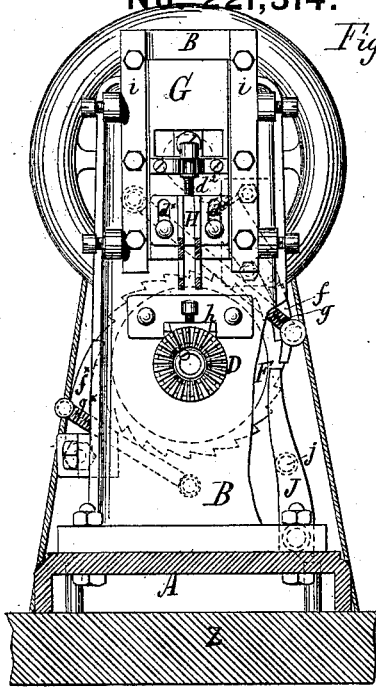

Fig. 4.

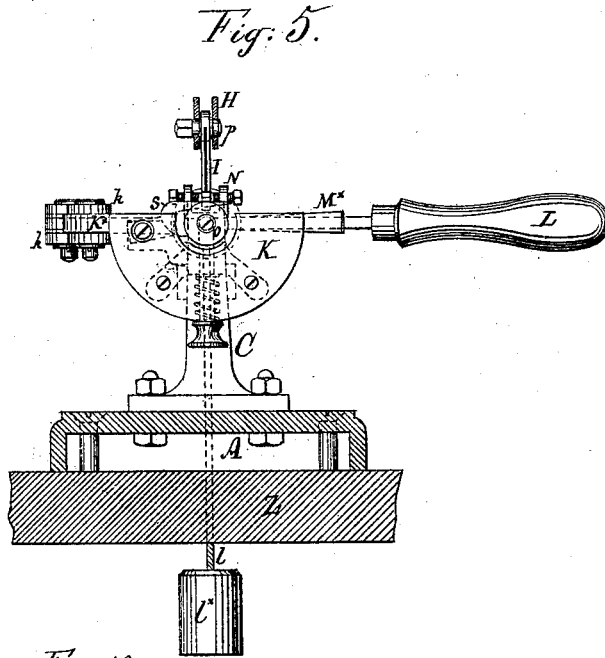

Fig. 5.

Fig. 6.

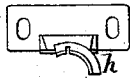

Fig. 7.

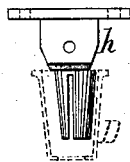

Fig. 10.

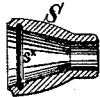
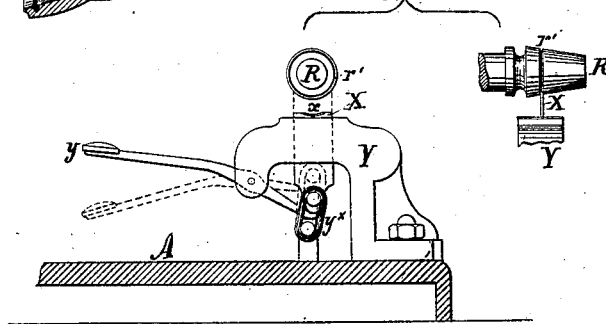

Fig. 11.



Witnesses.

Sweet de Pass
H. Manthe

Inventor.

William Frederick Hunt

W. F. HUNT.
Machine for Making Plaited Paper Caps, &c.
No. 221,314. Patented Nov. 4, 1879.

Fig. 8.

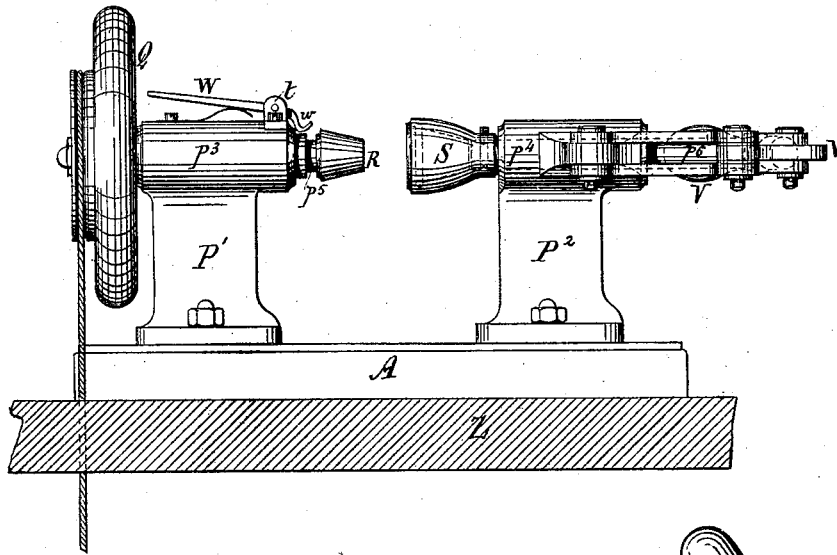
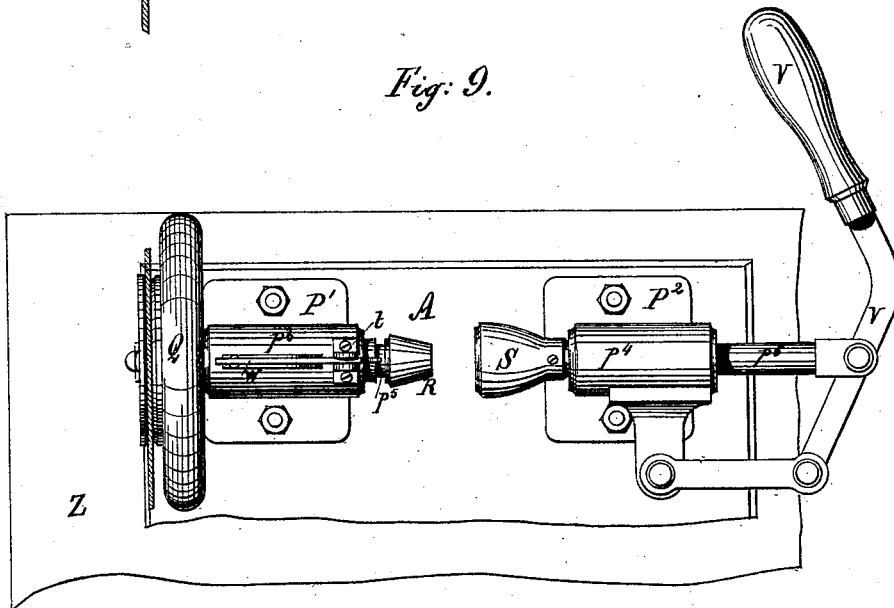

Fig. 9.



Witnesses
Ernest de Pass
W. Mauthner

Inventor
William Frederick Hunt

UNITED STATES PATENT OFFICE.

WILLIAM F. HUNT, OF LONDON, ENGLAND.

IMPROVEMENT IN MACHINES FOR MAKING PLAITED PAPER CAPS, &c.

Specification forming part of Letters Patent No. 221,314, dated November 4, 1879; application filed September 27, 1878.

To all whom it may concern:

Be it known that I, WILLIAM FREDERICK HUNT, of London, England, have invented certain new and useful improvements in the mode of and apparatus or machines for manufacturing plaited paper caps or capsules for bottles and like receptacles, also cups, cases, or holders for containing confectionery and like articles; and that I do hereby declare the following to be a full, clear, and exact description of the same.

This invention relates to improvements in machines or apparatus whereby I can effect the more expeditious manufacture of plaited paper caps or capsules for bottles and like receptacles, also paper cups, cases, holders, or other like receptacles for holding ices, custards, soufflés, ramequins, cheese, fruit, and other like articles or refreshments.

The accompanying drawings exemplify the manner in which the invention may be carried into practical effect.

Figure 1 is a front elevation of a machine constructed according to my invention, and employed for forming caps, cases, or holders for receiving table articles, such as ices, soufflés, custards, ramequins, as well as for making caps or capsules for bottles, jars, and other like receptacles. The machine is shown in this figure in its closed or working position. Fig. 2 is an elevation, showing the machine in its open position, ready for the introduction of a paper blank to be operated upon. Fig. 3 is a plan. Fig. 4 is a transverse section taken on the line B of Fig. 2. Fig. 5 is a transverse section, also taken on line B of Fig. 2, and showing, in front elevation, the plate or rest on which the paper blanks are placed. Fig. 6 shows a plan, and Fig. 7 an end view, of the adjustable slotted plate or arm. Fig. 8 is a side elevation, and Fig. 9 a plan, of the molding and indenting machine, by which the edge of the cap, &c., is folded or indented. Fig. 10 is a sectional detached view of the matrix for molding the cap or cup. Fig. 11 shows the device for turning the edge of the article outward.

A is the base or bed plate, which is secured to a platform, bench, or table, Z, and B is a stationary upright frame fixed to the bed-plate A. *a* is an axis passing through the upright

B and carrying a hollow slotted drum, D. This drum, which is closed at its outer end, is formed with a number of longitudinal slots on its periphery, cut close together and all of one size or gage. It receives rotary motion from the pulley E, which is worked by treadle or steam power, and which works the ratchet-wheel F, also mounted on the axis *a* of the slotted drum.

On the axis *e* of the pulley E is a cam, *e*^x, for depressing a jointed spring-pawl, *f*, and forcing it to engage in the teeth of the ratchet-wheel, and so depress them, whereby this wheel is forced to revolve, and with it the slotted drum.

A second jointed spring-pawl, *f*^x, acting in the contrary direction to *f*, enters the teeth of the ratchet-wheel on the opposite side and equalizes the intermittent movement of the axis, and regulates the revolution of the ratchet-wheel. *g g*^x are springs secured to projecting arms for keeping the pawls *f* and *f*^x to their work.

The ratchet-wheel has as many teeth as there are slots in the drum, so that for each tooth moved by the pawl *f* the drum is moved one slot. It is immaterial which way the pulley is caused to revolve; the ratchet-wheel will always turn in one and the same direction, because the pawl *f*, being stationary, compels it so to do.

Upon the opposite end of the axis of the pulley E is an eccentric pin or stud, *e*², which imparts motion to a vertical slide, G, working in laterally-adjustable guides *i i*, attached to the upright B. To this slide G is secured a vertical adjustable slotted nose-piece, guide-arm, or projection, H, with which a reciprocating blade, I, hereinafter referred to, is in constant connection, and whence it receives up-and-down motion.

h is an adjustable slotted plate or arm secured to the upright B, and lying or projecting within the slotted hollow drum D. This plate is of curved and suitable shape, as shown in Figs. 6 and 7, to correspond with the internal contour of the drum. It lies next to but not in contact with the internal periphery of the drum, so that a space is left between its upper surface and the inner surface of the drum. It may be rendered both vertically and laterally adjustable, so that it may be

placed, relatively to the slots of the drum, in such manner as to suit the required size and depth of plaits or depression, and it is curved, because such shape is well adapted for retaining the plaits under pressure as long as possible; also, because it can act as a guard to protect the material under treatment from coming in contact with a heating agent, should such be employed. It extends under a portion of the slotted drum for a greater depth or greater portion of circumference on one side than on the other; but, if desired, it may extend to nearly the whole circumference of the drum, so long as sufficient space or opening is left to permit the material to be disengaged from the drum.

The function of the slot in the plate *h* is to receive the portion of paper pushed between the bars of the slotted drum at each dip of the blade or pusher. The slot in the arm *h* being rigid, while the slots formed by the bars of the drum revolve, causes the pinch or fold of the paper between the inner periphery of the drum and the outer edge of the arm *h* as the drum is rotated. I call this arm or plate a "compressor," because it exerts a compressing action.

H is the slotted nose-piece or guide, hereinbefore referred to. It is composed of two parallel slotted plates kept a certain distance apart by a *T*-piece, and to which the plates are secured. These parallel plates keep the blade always in its proper direction and prevent it from moving laterally.

The nose-piece is secured to the slide *G*, and is adjustable vertically, so as to regulate the depth of dip of the blade. It is kept in place by set-screws passing through the slots *d*^x *d*^x in the *T*-piece, and entering the slide *G*. Its adjustment is regulated by the screw *d*² entering the *T*-piece and passing through a collar attached to the slide.

In order to prevent the dipping blade breaking the bars of the slotted drum when the main axis becomes loose in its bearing, which occurs after very little wear of the machine, and backlash takes place in the ratchet-wheel, I fix to the base-plate two upright bars or arms, *J J*, forming nippers or pinchers, and which gripe the wheel and keep it in position on its axis. A screw, *j*, passing through these bars or arms regulates the gripe. As the screw is revolved the bars or arms are forced to gripe the wheel more tightly, and by thus keeping it well held up backlash is prevented. This simple contrivance is most essential, and forms an important feature in my improvements.

C is a support or frame, fixed to the bed-plate *A*, and provided with a socket or eye, *e*^x, through which passes a rod, *e*. To the inner end of this rod is fitted the receiving-plate or rest *K*, for carrying the blanks or disks of paper, and at its outer end it is forked to receive a lever-handle, *L*, for working it, with the receiving-plate or rest, to and fro.

To a projection, *K*^x, on the socket *e*^x two

parallel arms or bars, *kk*, are pivoted, to which the end of the lever *L* is attached.

l is a cord passing over a grooved wheel, *m*, mounted on the support *C*, and passing through the bed-plate *A* and platform *Z*. It is provided with a counterbalance-weight, *l*^x, at one extremity, and at its other extremity it is attached to an eye, *l*², under the fork.

M is a stop centered in the fork of the rod *e*, for preventing the weight *l*^x descending when the lever-handle is drawn back, and in its open position it is furnished with a spring finger-piece, *M*^x, which, on being pressed toward the handle, releases the stop and causes it to enter a recess in the rod or spindle formed therein for its reception, and as it lies within this rod the weight descends and the receiving-plate is brought up to the end of the slotted drum.

I is a rocking or dipping blade. It is pivoted to a movable forked bearing, *N*, terminating in a shank, and maintained in the piece or block *N*^x at the end of the rod *e*, to which the receiving-plate is fixed. Around the shank of the forked bearing is a coiled spring, *n*, for helping its return or down stroke after its elevation, caused by the action of the reciprocating or dipping blade.

p is a screw-stud for regulating laterally the position of the dipping or rocking blade *I*. It passes through this blade, and is engaged in the slot in the nose-piece or slotted plate *H*, and keeps the said blade always in connection with the nose-piece, thus enabling the machine to be kept continuously in motion, and obviating its stoppage each time a fresh blank or disk of paper is introduced, in order to engage the dipping-blade in the nose-piece.

s is an adjustable transverse bar of wedge shape, having its upper and lower edges inclined. It is fixed to the piece *N* in such position that one end of the dipping or rocking blade *I* rides or oscillates over it when in action.

o is a metal disk, having a surface or disk of india-rubber, *o*^x, attached thereto, and revolving freely on an axis centered in a block or piece, *L*^x. The disk or blank of paper to be made into a cap, cup, or other like article rests against the india-rubber surface or disk *o*^x, which is caused to turn, with its blank of paper, by the friction received from the revolving drum.

When the machine is to be worked it is set in motion by a treadle, or by hand, steam, or otherwise, and as the pulley *E* revolves it communicates vertical reciprocating motion to the slide *G*, carrying the slotted plate or nose-piece *H*, and as—the lever-handle *L* having been previously drawn back and a paper blank or disk placed on the receiving plate or bed *K*—the finger-piece *M*^x is now depressed, and the stop entering the spindle, the counterbalance-weight *l*^x immediately descends and causes the receiving-plate, which is carried by the rod or spindle *e*, to be brought up to and against the end of the slotted drum *D*.

As the dipping or rocking blade I is in connection with the nose-piece H, and in motion from the starting of the machine, this blade is caused to push the paper blank into the slots of the drum at every tooth of the ratchet-wheel F moved.

The blade riding over the wedge-shaped bars *s* is so arranged as to enter more deeply at the inner end of the drum, and at each dip of the blade into the slot it pushes or presses therein a portion of the paper blank to be formed into a plait or fold. The portion of the paper pushed in is then caught between the compressor or curved plate *h* and the inner edge of the slot, and as the drum revolves the under surface of the paper of the interval between every two slots is formed into a plait. The plait is released as soon as the revolution of the drum clears it from the pressure of the compressor.

The drum having performed a complete revolution, the cup or holder is formed, and it is then withdrawn from the drum and placed on the molding-machine to have its edge folded or indented. This molding or indenting machine or apparatus may be mounted on the same bed-plate as the plaiting-machine, and it may be driven by the same motor; or it may receive its motion either from the plaiting-machine, or direct motion may be imparted to it, and in such case it may then communicate its motion to the plaiting-machine. It may be detached from the plaiting-machine if found more convenient for use, and it is shown detached in the drawings, in order that it may be more clearly seen.

On the base-plate A are mounted two supports, P' P², provided with sockets *p*³ *p*⁴. A rod, *p*⁵, passes through the socket *p*³, and is provided with a driving-pulley, Q, at its outer extremity, and at its inner extremity it is furnished with a suitably-shaped block or mandrel, R.

A forked rod, *p*⁶, passes through the socket *p*⁴, and is provided at its inner end with a matrix or cup, S, and at its outer end it is fitted with a lever-handle, V, for bringing the matrix S onto the block R. This matrix is formed with a groove or recess, *s*^x, around its inner edge. (See Fig. 10.)

The working is as follows: The lever-handle is first drawn back, and the plaited case or cup is held in front of the block, and the rod with the matrix is then brought forward by moving the handle. As the matrix comes in contact with the cup or cap it pushes it onto the block, and at the same time it completely surrounds the said case or cup, and while molding it to the required shape helps to flatten the plaits.

When the article is to receive a partial inwardly turned or folded edge, a spring presser, marker, or scorer, W, centered in a bearing, *t*, on the top of the socket *p*³, and having a blunt upturned edge, *w*, is caused to rise when its opposite end is lowered by the operator, and

to mark or indent the edge of the paper cup by forcing it into the groove or recess *s*^x in the matrix. The article may now be removed if desired, or, by a sudden backward and forward movement of the lever-handle V, the edge may be turned completely inward. The block R is, of course, shaped to correspond with the matrix which surrounds or covers it, and passes beyond the groove. The edge being turned in, the article is finished and is ready for use.

When the edge of the article is to be turned outward, as for caps or capsules for bottles, the horizontal spring marker, presser, or scorer is replaced by an upright blade, X. This blade has a depression or concavity, *x*, on its edge for a portion of its width, so as to fit into the corresponding portion of the groove *r*' on the block. It is mounted in a bearing, Y, on the base-plate A, and is operated by a key, *y*. This arrangement is shown in fragmentary view, Fig. 11, the same letters of reference indicating similar parts to those in Figs. 8 and 9.

As the key *y* is depressed the blade X rises and presses the paper into the annular groove *r*', which, for this purpose, is formed in the block, and is not covered by the matrix. An india-rubber ring, *y*^x, acting as a spring restores the blade to position on the key being released.

Although the drawings show a plaiting-machine in which the hollow slotted drum is conical, a cylindrical or other suitably-shaped slotted drum may be employed.

I claim as my invention and desire to secure by Letters Patent—

1. The combination of the hollow drum D, having closed outer end and a number of longitudinal slots in its periphery, pulley E, and ratchet-wheel F, having teeth corresponding in number to the slots in the drum, substantially as and for the purpose set forth.

2. The combination of the rocking or dipping blade or pusher I and slotted drum D, as and for the purpose set forth.

3. The combination of the slotted nose-piece or guide H, dipping blade or pusher I, and slide G, as and for the purpose set forth.

4. The combination of the internally-slotted curved arm, plate, or compressor *h* and the slotted drum D, as and for the purpose described.

5. The arrangement and combination of the rocking or dipping blade or pusher I, pivoted to a movable forked bearing, with the vertically-adjustable slotted arm, plate, or nose-piece H, substantially as and for the purpose set forth.

6. The arrangement and combination of the slotted drum D, rocking or dipping blade or pusher I, and internal slotted arm or compressor *h*, substantially as set forth, for the purpose described.

7. The combination of the springs *g* *g*^x, secured to projecting arms, and the jointed spring-pawls *f* and *f*^x, for regulating the revolution of the ratchet-wheel and preventing the

breaking of the bars of the hollow slotted drum by the dipping blade on its descent, as explained.

8. The combination, with the matrix S, having at its inner edge an annular groove or recess, s^8 , of forked rod p^6 , block R, and levers V and W, substantially as and for the purpose described.

9. The spring presser, marker, or scorer W, centered in a bearing on the socket p^3 , and having a blunt upturned edge for turning the edge of the cap, as explained, in combination with the internal annular grooved matrix for forming or scoring an indentation around the edge of the cap, cup, or other similar article, substantially as set forth.

10. The combination of the hollow slotted drum D, dipping blade or pusher I, compressor h , slotted guide H, and ratchet-wheel F, the

whole being constructed, arranged, and operated substantially as and for the purpose set forth.

11. The combination of the horizontal spring-marker W, mandrel R, and matrix S, substantially as and for the purpose set forth.

12. The combination of the block or mandrel R, vertical scoring-blade X, key or lever y , and matrix S, substantially as and for the purpose set forth.

Witness my hand this 22d day of February, 1878.

WILLIAM FREDERICK HUNT.

Witnesses:

ERNEST DE PASS,
68 *Fleet Street, London.*

JOHN DEAN,
17 *Gracechurch Street, London.*